

Installation, Operation, Maintenance, Troubleshooting.



OMC2375 / OMC2375CV

Mobile Cabinets

Table of Contents

WARRANTY	3
Technical Specifications	3
Weight & Dimensions	4
Operator's Instructions	5
Purging your system	9
Troubleshooting	10
Installation instructions	11
Utility center plumbing layout	12

TPC Warranty

Warranty Information (All stated warranties are intended for USA market ONLY): All of our products sold are guaranteed to be free from defects in workmanship and materials for one year from date of purchase, unless otherwise stated. TPC will repair or replace any defective part at no charge. TPC will not be responsible for labor charges or shipping charges to / from the TPC facility. This guarantee does not cover normal wear or stains on surface finish. The guarantee does not cover damage resulting from improper installation, misuse or accidents incurred in shipping and handling. All claims against the freight carrier must be initiated at the time the damaged items are received. The claim is the responsibility of the customer. We are improving our products on a continuous basis. We reserve the right to make modifications without the need for prior notification and are not obliged www.tpcdental.com – Page 1 – Products: Warranty Period: Products: Warranty Period: Patient Chairs 5 year limited Delivery Units 5 year Limited Operatory Lights (halogen) 1 year Seating 1 year Curing & Bleaching Systems 1 year Mobile Cabinets 1 year Imaging Products 1 year Air-Driven Handpieces 1 year Scaling Products 1 year Amalgamator 1 year Extended Manufacturer Warranty (selective models): Limited Manufacturer Warranty (selective models): H6000, H6005, H6025, H7005 Lubrication System 2 year 6 month Manufacturer Warranty (selective models): LED Curing Lights (All Models) 2 year Fiber optic systems, S333, M333, QS222, QM222, ELCA760, Advance CAM Intraoral Camera System(s) 2 year ELS736. Radiant Operatory Lights 2 year

Important Information

Technical Specifications

Air Regulator Pressure: 80 PSI^[SEP]

Water Bottle Regulator Pressure: 35-40 PSI^[SEP]

Handpiece Pressure: 30-35 PSI (for most high-speed handpieces)

40-45 PSI (for most low-speed handpieces)

CAUTION: When adjusting the handpiece pressure, do not over tighten the adjustment knobs. This may result in unnecessary damage to the handpiece control block.

- Pay careful attention when unpacking the delivery cart and its accessories. Damage caused by mishandling the equipment during unpacking or installation is not covered under warranty.

Mobile Cabinets

Weight & Dimensions Shipping Information

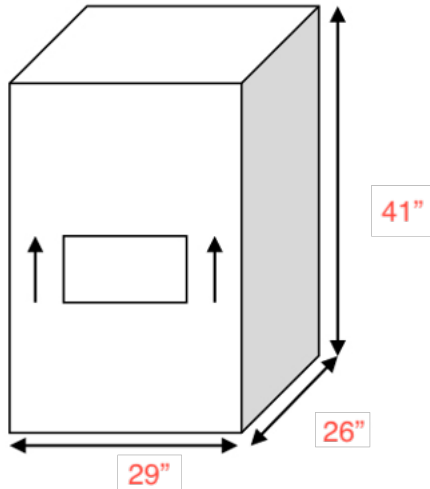

OMC2375 Ships on a pallet 225LBS

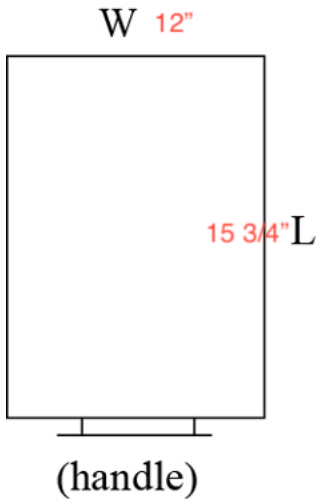

Cabinet Top Dimensions

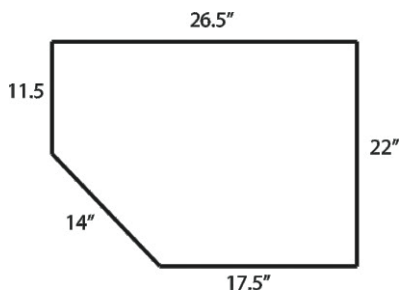

Mobile Cabinets

Operator's Instructions

- A. MASTER ON/OFF SWITCH: Opens and closes the valves in the floor-mounted Utility Box, supplying air to the complete system. Shut off nightly.

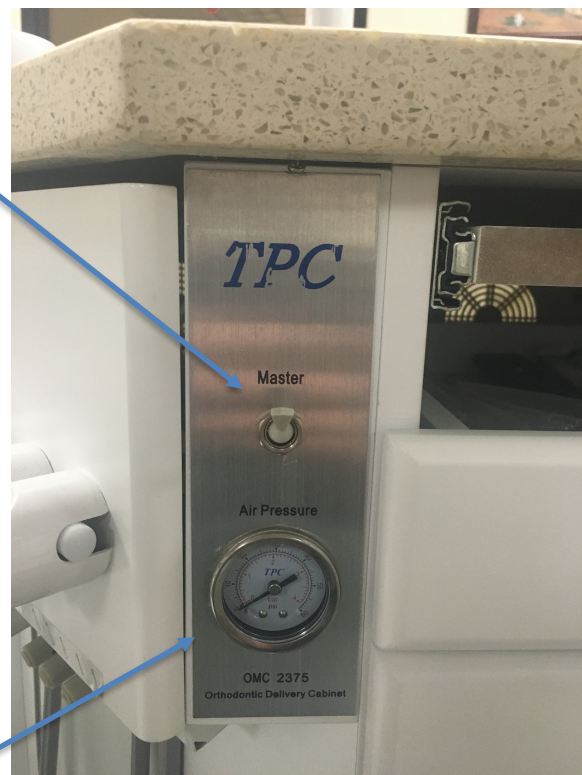

- B. HANDPIECE PRESSURE GAUGE: Indicates pressure adjusted by the Drive-Air Control Knob. Avoid exceeding the manufacturer's recommended handpiece pressure. (30 - 35 PSI for most Highspeed Handpieces)

(40 - 45 PSI for most Lowspeed Handpieces).

Mobile Cabinets

Operator's Instructions

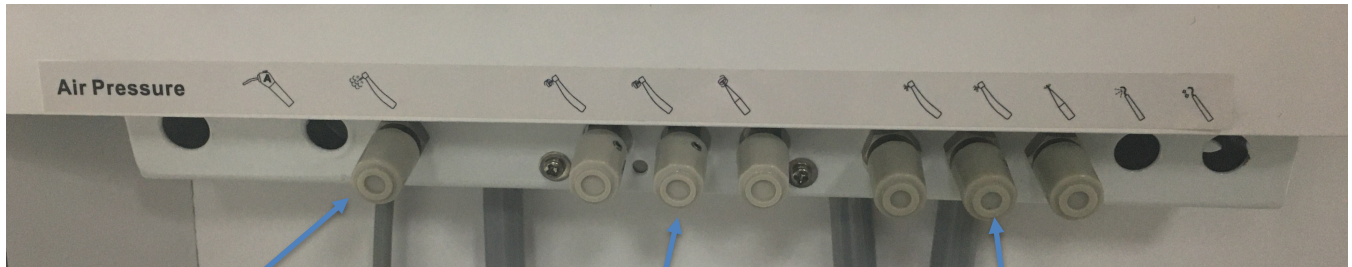

Chip Air

Handpiece Pressure

Water Adjustment

- A. Chip Air: This adjustment knob controls the chip air to the HP Tubing's.
- B. Handpiece Pressure: Adjusts the Handpiece pressure to the Handpieces.
- C. Water Adjustment: Controls the water flow to each handpece position.

Foot control wet dry toggle: When toggled to the left the water is off. Toggle to the right and water is turned on to the HP block.



Mobile Cabinets

TPC

Daily Maintenance Purging Your System

Purging with air: At the end of every day, the lines should be purged with air to prevent the growth of biofilm.

Remove handpieces from tubing.

Empty the water bottle, then reinstall it (if water bottle is applicable, when using city water, turn off water from the source).

Hold the handpiece tubing and syringe over a pail. Turn the unit on, press down on the syringe and foot control until water is purged from the system.

Turn unit off.

Disinfecting the bottle (if applicable): Fill the bottle with 100 ml disinfectant solution, shake vigorously and let settle for 10 minutes. Shake again, and then rinse twice with water.

Weekly Maintenance

The weekly cleaning procedure should be performed at least once a week, preferably at the start of the week before treating patients. If the unit is stored for any length of time, perform the weekly maintenance routine immediately before and after storage.

- Purge the unit with air (see Daily Maintenance).
- Flush the system with disinfectant solution a. Turn unit off. Empty the water bottle (if water bottle is applicable), replacing the water with cleaning solution (see Disinfectant Solution). Remove handpieces from tubing and hold the handpiece tubing and syringe over a pail. Turn unit on, wait a few moments and then operate the flush toggle (if applicable), syringe and foot control until a continuous stream of solution is running through the system. Allow the disinfectant to remain in the unit for at least 10 to 20 minutes and then flush the system again until all the solution is used.

Mobile Cabinets

- Purge the unit with air:

Hold the handpiece tubing and syringe over a pail. Turn the unit on, wait a few moments and then press the syringe and foot control until all solution is purged from the system.

Turn unit off. (If the unit is to be stored, stop here.)

Fill with clean water:

- a. With the unit turned off, remove the empty disinfectant bottle (if applicable). Replace with a clean bottle and water.
- b. Hold Remove handpieces from tubing and hold the handpiece tubing and syringe over a pail. Turn unit on, wait a few moments and then press the syringe and foot control until a continuous stream of solution is running through the system.

Disinfectant Solution: Use 100 ml (9 parts tap water & 1 part 5.25% Sodium hypochlorite (household bleach) of disinfectant solution for each application per week. Always use a fresh mixture every week.

TPC

Troubleshooting Guide

SYMPTOM

PROBABLE CAUSE

1. Handpiece Lacks Power

- A. Check regulator adjustment (80 psi).
- B. Check handpiece pressure adjustment on control block.
- C. Plugged air filter.
- D. Pinched supply tubing. Check for kinks.
- E. Bad handpiece gasket at connection with tubing.
- F. Defective handpiece.
- G. Damaged Tri Block Diaphragm

2. Water coolant does not shut off when the Foot Control is released.

- A. Verify master air regulator is set to 80 psi - water pressure to 40 psi.
- B. Foot Control is not exhausting.
- C. Defective water relay in valve.
- E. Pinched water relay signal air-line.

3. More than one handpiece is operating.

- A. Handpiece is not completely in the hanger.
- B. Improper adjustment of Pilot Valve in the hanger.
- C. Kinked or pinched signal line from the Pilot Valve.
- D. Damaged Tri Block diaphragm.

Mobile Cabinets

4. Water coolant is running from handpiece while in holder.

- A. Purge switch is on (on applicable systems).
- B. Water pressure is too high.
- C. Handpiece holder out of adjustment.
- D. Improper adjustment of water relay.

5. Insufficient water coolant.

- A. Adjust coolant flow valve.
- B. Water filter may be plugged.
- C. Plugged handpiece.
- D. Kinked or pinched tubing.
- E. Improper adjustment of water relay.

6. Water coolant is running continuously.

- A. Water pressure is too high.
- B. Air pressure is too low.
- C. Handpiece holder out of adjustment.

7. Syringe Air / Water pressure is low.

- A. Water pressure / air pressure are set too low check master control regulators.
- B. Damaged syringe cartridges.
- C. Pinched syringe tubing.

Installation

1. Un-pack cabinet and place in desired location.
2. Install the solids collector trap to the bracket located on the left side of the cabinet. Prior to securing the trap, you will need to connect the vacuum line to the side port of the cannister.
3. Connect the air pilot valve for the air supply in the utility center.
4. Open the angle stop and verify the master regulator is set to 80 PSI.
5. Connect the central vacuum line from the umbilical to the utility center.
6. Open the back-access door of the cabinet and remove the water bottle from the bottle cap assembly. Fill the bottle with water, then re install into bottle cap assembly.
7. Turn the master switch to the “On” position.
8. Test the air and water pressure to the Syringe and the HP tubings.
9. Pressure adjustments may be made on the front panel of the cabinet if the pressure is not sufficient.

Junction box template

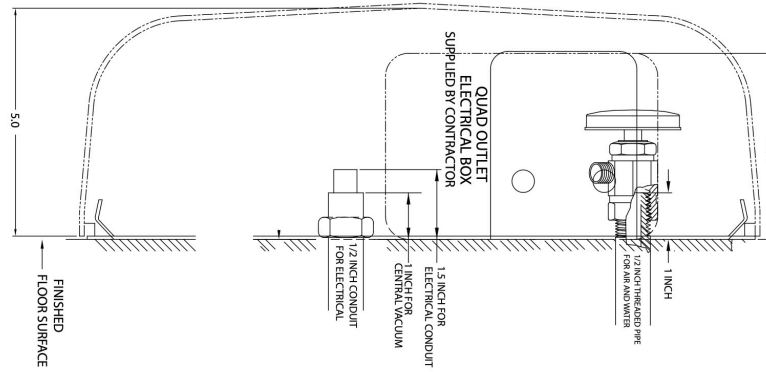

12"

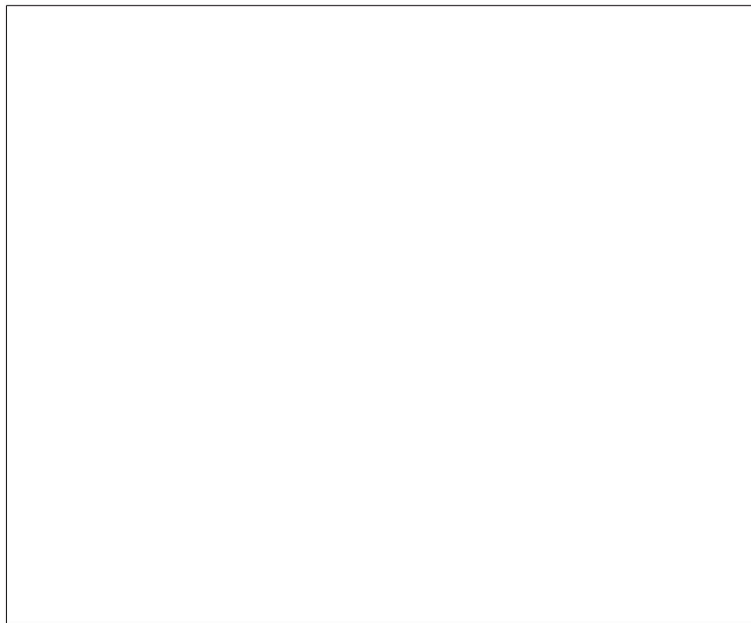

Mobile Cabinets